



A Division of:
Light Engineered Displays, Inc.
109 Portwatch Way
Wilmington, N.C. 28412
Phone: (800) 251-2512
Fax: (800) 251-9878
Internet: www.ledinc.com
Email: sales@ledinc.com



Specifications

- **Power Input**
115 VAC, 60 HZ .5 AMP.
- **Operating Voltage**
12 VDC, Internal 12 VAC
54 HZ Detection Loop
- **Battery Backup**
12 VDC, 1.2 amp/hr battery
with automatic charger
- **Indicators**
LED Type, for Alarm, Trouble and
Power On status
- **Outputs**
Sonalert and Form-C contacts

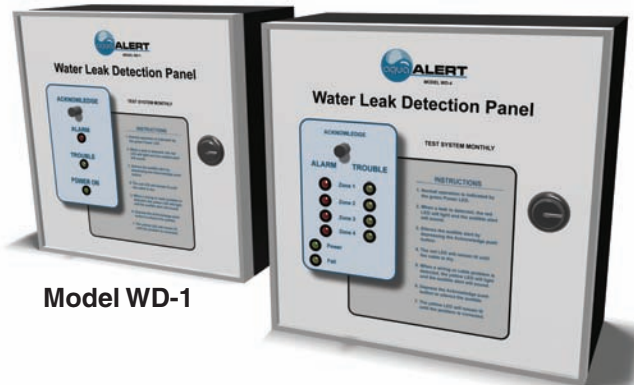

Model WD-1

Model WD-4

General Description

The AquaALERT water detection system, featuring models WD-1 and WD-4, is specifically designed for water leak detection in concealed areas or any place water intrusion must be identified immediately so that corrective action can be taken.

Applications would include Electrical or Telephone Equipment rooms, Computer Room subfloors, or any sensitive area that is not normally occupied. Additionally, this system can be used to detect leaks along fluid piping lines. Also, fluid levels can be detected with our optional float switches (see the 6200 Series cutsheet located in the Miscellaneous section of our catalog).

The unit is housed in a metal backbox, with a key-lockable plexiglass door. All indicators and switches are visible from the front of the unit.

The system is designed to work with AquaALERT water detection cable, model WDC-100. Low voltage A.C. is used to supervise the detection loop. This eliminates Electrolysis of the sensing wires woven within the detection cable, a common problem with other systems.

Basic Operation

The WD Series Water Detection System contains one or four fully supervised detection zone(s). The circuit must be terminated at the end of the line with a 15K Ohm, 1.2 Watt resistor.

Normal (standby) operation is indicated by a green "Power On" LED.

An Alarm condition occurs when water comes in contact with the Water Detection cable. A Trouble condition occurs when the wiring to the sensor, or the wires within the cable, are broken.

When an Alarm condition occurs, the Red LED will light, the Sonalert will sound, and the Aux. relay contact will close. The Sonalert can be silenced by operating the momentary Acknowledge switch. The Red LED will remain lit until the Alarm condition is corrected. At that time, the LED will reset itself. The sequence is the same for a Trouble condition, except a Yellow LED will be illuminated. Multiple Zone Units have subsequent alarm features.



ZONE LEAK DETECTION SYSTEM

Architect/Engineer Specification

The Contractor shall furnish, where indicated on the plans, a Water Leak Detection System. The standard features shall include but not be limited to the following:

1. The system shall utilize linear water leak detection cable.
2. The system shall utilize limited power, low voltage A.C. for the detection circuits to protect the leak detection cable from damage by electrolysis.
3. The system shall supervise the wiring and the water sensing conductors embedded in the leak detection cable. Any break in the wiring shall cause a System Trouble indication at the leak detection control panel.
4. The system shall also include both Alarm and Trouble indications for each input zone as was as a common audible alarm and auxiliary form-C contacts for connection to external monitoring systems.
5. System inputs shall have adjustable sensitivity to allow for proper operation over a broad range of ambient field conditions.
6. The control panel shall operate from 115 V.A.C. and shall include automatic battery backup using a 12v gel - cell battery. The panel assembly is housed in a steel enclosure with hinged door and cam lock to prevent unauthorized access.
7. The system shall be Model WD-1 / -4 -8 -16 (specify) as manufactured by AquaALERT, a division of LED Incorporated.

Circuit Board & Enclosure Details

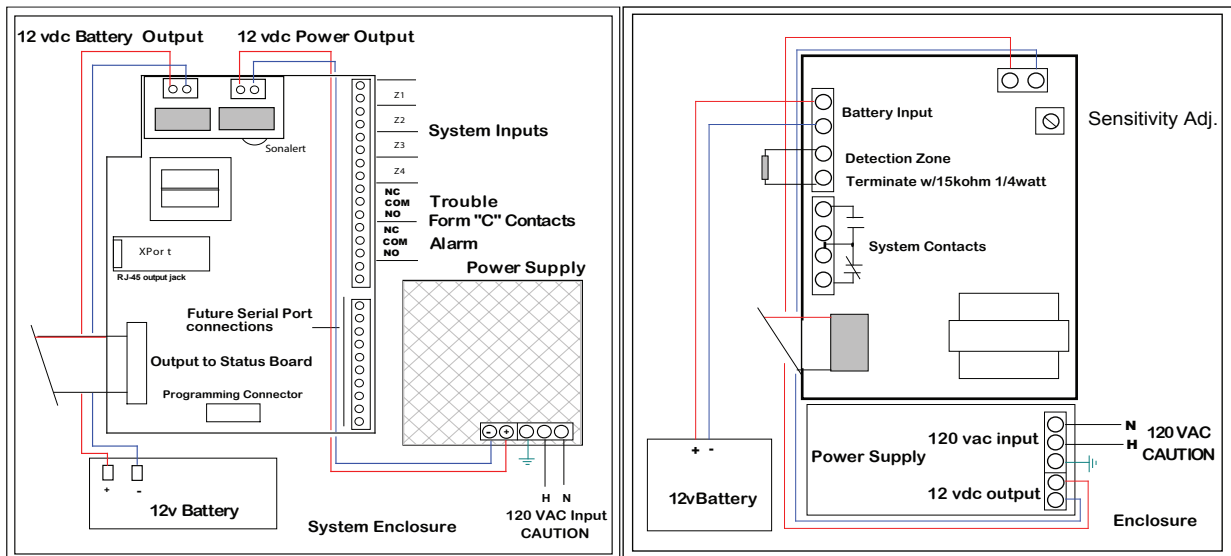

WD-4

WD-1

NOTES:

Nominal power is 115v AC - 60hz - 500ma. Route power away from all class-2 wiring. Power supply is a universal type with an input voltage range of 85 -264v AC and 47 to 63hz. Output is approximately 13.5v DC, 2 amps max with self-restoring overload protection.

Standby power is provided by a 12v 1.5 amp/hr gelled electrolyte battery. System Alarm and Trouble contacts are rated for 1amp resistive load, max. (class 2) Relays shown de-energized. Each leak detection zone must be terminated with a 15K ohm resistor.

